

MPA 401 Series

Mini Power Amplifiers



Extron Electronics
INTERFACING, SWITCHING AND CONTROL

Safety Instructions

Safety Instructions • English

WARNING: This symbol, ⚠, when used on the product, is intended to alert the user of the presence of uninsulated dangerous voltage within the product's enclosure that may present a risk of electric shock.

ATTENTION: This symbol, ⚠, when used on the product, is intended to alert the user of important operating and maintenance (servicing) instructions in the literature provided with the equipment.

For information on safety guidelines, regulatory compliances, EMI/EMF compatibility, accessibility, and related topics, see the Extron Safety and Regulatory Compliance Guide, part number 68-290-01, on the Extron website, www.extron.com.

Instructions de sécurité • Français

AVERTISSEMENT: Ce pictogramme, ⚠, lorsqu'il est utilisé sur le produit, signale à l'utilisateur la présence à l'intérieur du boîtier du produit d'une tension électrique dangereuse susceptible de provoquer un choc électrique.

ATTENTION: Ce pictogramme, ⚠, lorsqu'il est utilisé sur le produit, signale à l'utilisateur des instructions d'utilisation ou de maintenance importantes qui se trouvent dans la documentation fournie avec le matériel.

Pour en savoir plus sur les règles de sécurité, la conformité à la réglementation, la compatibilité EMI/EMF, l'accessibilité, et autres sujets connexes, lisez les informations de sécurité et de conformité Extron, réf. 68-290-01, sur le site Extron, www.extron.fr.

Sicherheitsanweisungen • Deutsch

WARNUNG: Dieses Symbol ⚠ auf dem Produkt soll den Benutzer darauf aufmerksam machen, dass im Inneren des Gehäuses dieses Produktes gefährliche Spannungen herrschen, die nicht isoliert sind und die einen elektrischen Schlag verursachen können.

VORSICHT: Dieses Symbol ⚠ auf dem Produkt soll dem Benutzer in der im Lieferumfang enthaltenen Dokumentation besonders wichtige Hinweise zur Bedienung und Wartung (Instandhaltung) geben.

Weitere Informationen über die Sicherheitsrichtlinien, Produkthandhabung, EMI/EMF-Kompatibilität, Zugänglichkeit und verwandte Themen finden Sie in den Extron-Richtlinien für Sicherheit und Handhabung (Artikelnummer 68-290-01) auf der Extron-Website, www.extron.de.

Instrucciones de seguridad • Español

ADVERTENCIA: Este símbolo, ⚠, cuando se utiliza en el producto, avisa al usuario de la presencia de voltaje peligroso sin aislar dentro del producto, lo que puede representar un riesgo de descarga eléctrica.

ATENCIÓN: Este símbolo, ⚠, cuando se utiliza en el producto, avisa al usuario de la presencia de importantes instrucciones de uso y mantenimiento recogidas en la documentación proporcionada con el equipo.

Para obtener información sobre directrices de seguridad, cumplimiento de normativas, compatibilidad electromagnética, accesibilidad y temas relacionados, consulte la Guía de cumplimiento de normativas y seguridad de Extron, referencia 68-290-01, en el sitio Web de Extron, www.extron.es.

Chinese Simplified (简体中文)

警告: ⚠ 产品上的这个标志意在警告用户该产品机壳内有暴露的危险电压, 有触电危险。

注意: ⚠ 产品上的这个标志意在提示用户设备随附的用户手册中有重要的操作和维护(维修)说明。

关于我们产品的安全指南、遵循的规范、EMI/EMF 的兼容性、无障碍使用的特性等相关内容, 敬请访问 Extron 网站 www.extron.cn, 参见 Extron 安全规范指南, 产品编号 68-290-01。

Chinese Traditional (繁體中文)

警告: ⚠ 若產品上使用此符號, 是為了提醒使用者, 產品機殼內存在著可能會導致觸電之風險的未絕緣危險電壓。

注意: ⚠ 若產品上使用此符號, 是為了提醒使用者。

有關安全性指導方針、法規遵守、EMI/EMF 相容性、存取範圍和相關主題的詳細資訊, 請瀏覽 Extron 網站: www.extron.cn, 然後參閱《Extron 安全性與法規遵守手冊》, 準則編號 68-290-01。

Japanese

警告: この記号 ⚠ が製品上に表示されている場合は、筐体内に絶縁されていない高電圧が流れ、感電の危険があることを示しています。

注意: この記号 ⚠ が製品上に表示されている場合は、本機の取扱説明書に記載されている重要な操作と保守(整備)の指示についてユーザーの注意を喚起するものです。

安全上のご注意、法規遵守、EMI/EMF適合性、その他の関連項目については、エクストロンのウェブサイトwww.extron.jpより『Extron Safety and Regulatory Compliance Guide』(P/N 68-290-01)をご覧ください。

Korean

경고: 이 기호 ⚠ 가 제품에 사용될 경우, 제품의 인클로저 내에 있는 접지되지 않은 위험한 전류로 인해 사용자가 감전될 위험이 있음을 경고합니다.

주의: 이 기호 ⚠ 가 제품에 사용될 경우, 장비와 함께 제공된 책자에 나와 있는 주요 운영 및 유지보수(정비) 지침을 경고합니다.

안전 가이드라인, 규제 준수, EMI/EMF 호환성, 접근성, 그리고 관련 항목에 대한 자세한 내용은 Extron 웹 사이트(www.extron.co.kr)의 Extron 안전 및 규제 준수 안내서, 68-290-01 조항을 참조하십시오.

FCC Class B Notice

FC This equipment has been tested and found to comply with the limits for a Class B digital device, pursuant to part 15 of the FCC rules. These limits provide reasonable protection against harmful interference in a residential installation. This equipment generates, uses, and can radiate radio frequency energy and, if not installed and used in accordance with the instructions, may cause harmful interference to radio communications. There is no guarantee that interference will not occur. If this equipment does cause interference to radio or television reception, which can be determined by turning the equipment off and on, you are encouraged to try to correct the interference by one or more of the following measures:

- Reorient or relocate the receiving antenna.
- Increase the separation between the equipment and receiver.
- Connect the equipment into an outlet on a circuit different from that to which the receiver is connected.
- Consult the dealer or an experienced radio/TV technician for help.

NOTE: For more information on safety guidelines, regulatory compliances, EMI/EMF compatibility, accessibility, and related topics, see the “[Extron Safety and Regulatory Compliance Guide](#)” on the Extron website.

Copyright

© 2013 Extron Electronics. All rights reserved.

Trademarks

All trademarks mentioned in this guide are the properties of their respective owners.

The following registered trademarks[®], registered service marksSM, and trademarksTM are the property of RGB Systems, Inc. or Extron Electronics:

Registered Trademarks [®]
AVTrac, Cable Cubby, CrossPoint, eBUS, EDID Manager, EDID Minder, Extron, Flat Field, GlobalViewer, Hideaway, Inline, IP Intercom, IP Link, Key Minder, LockIt, MediaLink, PoleVault, PURE3, Quantum, SoundField, SpeedMount, SpeedSwitch, System Integrator, TeamWork, TouchLink, V-Lock, VersaTools, VN-Matrix, VoiceLift, WallVault, WindoWall
Registered Service MarkSM : S3 Service Support Solutions
Trademarks TM
AAP, AFL (Accu-Rate Frame Lock), ADSP (Advanced Digital Sync Processing), AIS (Advanced Instruction Set), Auto-Image, CDRS (Class D Ripple Suppression), DDSP (Digital Display Sync Processing), DMI (Dynamic Motion Interpolation), Driver Configurator, DSP Configurator, DSVP (Digital Sync Validation Processing), FastBite, FOXBOX, IP Intercom HelpDesk, MAAP, MicroDigital, PowerCage, ProDSP, QS-FPC (QuickSwitch Front Panel Controller), Scope-Trigger, SIS, Simple Instruction Set, Skew-Free, SpeedNav, Triple-Action Switching, XTP, XTP Systems, XTRA, ZipCaddy, ZipClip

Conventions Used in this Guide

Notifications

ATTENTION: Attention indicates a situation that may damage or destroy the product or associated equipment.

NOTE: A note draws attention to important information.

Specifications Availability

Product specifications are available on the Extron website, www.extron.com.

Contents

Introduction 1

- Important Safety Instructions 1
- MPA 401-70V and MPA 401-100V Description... 2
- MPA 401-70V and MPA 401-100V Features..... 3

Rear Panel and Cabling 4

- Rear Panel..... 4
- Power Input..... 5
- Audio Inputs 6
- Remote Input Port 7
- Speaker Connections 9

Setup and Operation 10

- Front Panel Features..... 10
- Setting Input Level..... 11
- Setting Bass and Treble..... 11
- Remote Control Options..... 12
- Troubleshooting 13
 - Amplifier Fails to Exit Standby Mode Promptly..... 13
 - Amplifier Enters Standby Mode Too Early..... 13

Reference Material 14

- Mounting 14
 - Plenum Placement..... 14
 - Tabletop Placement 14
 - Rack Mounting 14
 - Under-desk, Through-desk, and Projector Mounting..... 15

Introduction

This guide contains information about the Extron MPA 401-70V and MPA 401-100V mini power amplifiers with instructions for experienced installers on how to install, configure, and operate the equipment. Unless otherwise specified, references in this guide to the “amplifier,” “MPA,” or “MPA 401” relate to the features or operation of either amplifier.

This section provides the following information:

- [Important Safety Instructions](#)
- [MPA 401-70V and MPA 401-100V Description](#)
- [MPA 401-70V and MPA 401-100V Features](#)

Important Safety Instructions

1. Read these instructions.
2. Keep these instructions.
3. Heed all warnings.
4. Follow all instructions.
5. Do not use this apparatus near water.
6. Clean only with dry cloth.
7. Do not block any ventilation openings. Install in accordance with the instructions of the manufacturer.
8. Do not install near any heat sources such as radiators, heat registers, stoves, or other apparatus (including amplifiers) that produce heat.
9. Do not defeat the safety purpose of the polarized or grounding-type plug. A polarized plug has two blades with one wider than the other. A grounding type plug has two blades and a third grounding prong. The wide blade or the third prong are provided for safety. If the provided plug does not fit into the outlet, consult an electrician for replacement of the obsolete outlet.
10. Protect the power cord from being walked on or pinched particularly at plugs, convenience receptacles, and the point where they exit from the apparatus.
11. Only use attachments or accessories specified by the manufacturer.
12.  Use only with the cart, stand, tripod, bracket, or table specified by the manufacturer, or sold with the apparatus. When a cart is used, use caution when moving the cart/apparatus combination to avoid injury from tip-over.
13. Unplug this apparatus during lightning storms or when unused for long periods of time.
14. Refer all servicing to qualified service personnel. Servicing is required when the apparatus has been damaged in any way, such as if the power-supply cord or plug is damaged, liquid has been spilled or objects have fallen into the apparatus, the apparatus has been exposed to rain or moisture, does not operate normally, or has been dropped.

MPA 401-70V and MPA 401-100V Description

The Extron MPA 401-70V and MPA 401-100V integrated mini power amplifiers provide mono amplification for speaker systems that require compact and economical audio solutions. Both amplifiers accept balanced or unbalanced, stereo or mono inputs and provide a summed mono output. The MPA 401-70V delivers up to 40 watts (rms) for a high-impedance, 70 V distributed sound system. The MPA 401-100V delivers up to 40 watts (rms) for a high-impedance, 100 V distributed sound system.

Front panel controls allow easy adjustment of bass, treble, and input levels. Volume can be controlled remotely by the Extron VCM 100, VC 50, or MLA VC 10.

Both amplifiers feature high efficiency, Class D amplifier design with advanced CDRS (Class D Ripple Suppression) technology that eliminates EMI emissions and interference with sensitive AV equipment. The design allows the amplifiers to be fanless and operate in environments with little or no ventilation. Both amplifiers meet UL 2043 for smoke and fire code for above-the-ceiling installations.

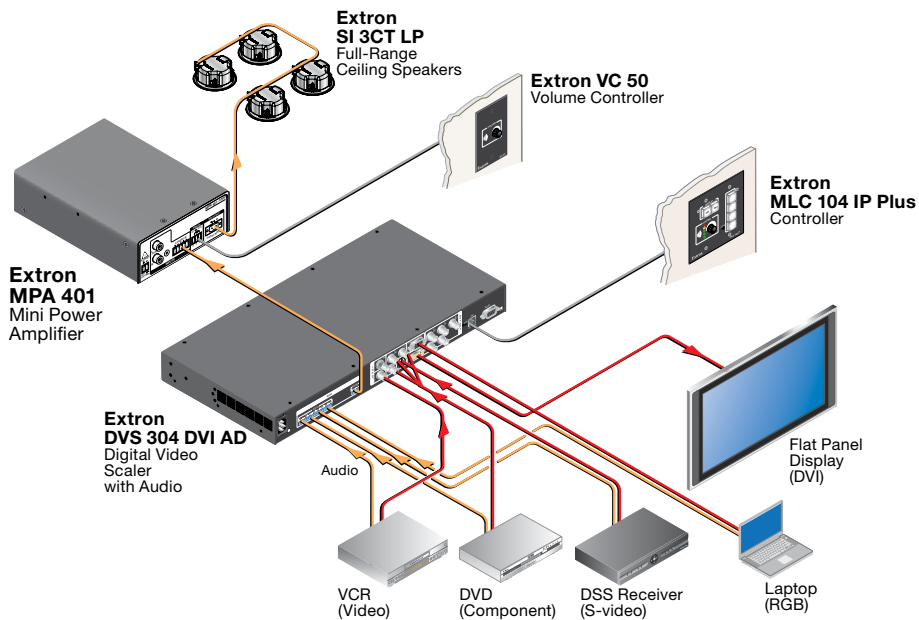

Figure 1. Typical Application for the MPA 401

MPA 401-70V and MPA 401-100V Features

Patented CDRS (Class D Ripple Suppression) — CDRS is an Extron patented technology that eliminates high frequency switching ripple and EMI emissions found in all Class D amplifiers. CDRS dramatically improves audio performance over conventional Class D amplifier designs and enables Extron power amplifiers to be situated near wireless AV devices without RF interference.

UL 2043 plenum rated — The amplifiers meet UL 2043 for smoke and heat release for installation within a plenum airspace above a drop ceiling. Above-the-ceiling placement conceals the amplifier to prevent theft and is convenient for installing equipment when space inside the room is limited.

Balanced and unbalanced buffered audio inputs — Both amplifiers accept balanced or unbalanced, stereo or mono audio input signals on a captive screw connector, and unbalanced audio on both RCA connectors and a 3.5 mm stereo mini jack.

The signals from multiple inputs are summed to produce a single output signal (see [figure 6](#) on page 9).

The three stereo inputs are individually buffered and can be connected to three separate sources at the same time without altering performance.

Quick-plug speaker outputs — Speaker output is on a 5 mm screw lock captive screw connector for quick installation.

ENERGY STAR® qualified amplifiers — The MPA 401-70V and MPA 401-100V amplifiers are ENERGY STAR qualified amplifiers and energy efficient products that conserve energy and reduce costs.

Auto power-down with fast power up — Automatically places the amplifiers into standby after 25 minutes of inactivity. They quickly return to full power status in less than one second upon signal detection. The amplifiers consume just 6 watts when idle and less than 1 watt in standby mode.

Front panel bass, treble, and input level controls — Bass, treble, and input level are easily adjusted from the front panel.

Fanless design — The amplifiers do not require fans or vents for cooling, ensuring quiet, reliable operation.

Automatic clip limiter — Detects actual onset of clipping by comparing input and output waveforms. Gain is automatically reduced with a slow attack and fast release to eliminate clipping. This advanced limiter design protects the speakers from clipping distortion and offers superior sonic characteristics compared to limiters that use signal compression.

Remote volume and mute control port — A rear panel, three-pin captive screw remote input connector allows remote adjustment of volume and muting. In basic installations without third-party control systems, this port allows the amplifiers to be remotely controlled using the optional Extron VCM 100 series analog volume and mute controller or VC 50 analog volume controller.

Compact size — The 1U, quarter rack width, 6 inch deep metal enclosure, offers flexible mounting options.

Rear Panel and Cabling

This section describes the rear panel features and cabling of the MPA 401-70V and MPA 401-100V.

- [Rear Panel](#)
- [Power Input](#)
- [Audio Inputs](#)
- [Remote Input Connector](#)
- [Speaker Connections](#)

Rear Panel

The illustration below shows the rear panel of the amplifiers:

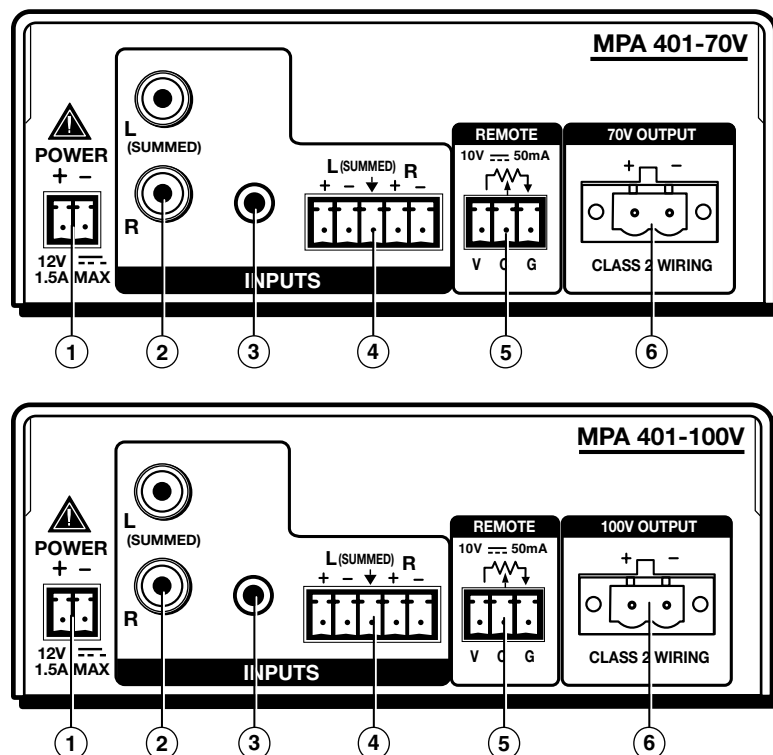

Figure 2. MPA 401-70V and MPA 401-100V Rear Panel Features

NOTE: Control signal ground pins may be labelled \oplus , \downarrow , or G. Audio ground pins may be labelled \oplus or \downarrow . The wiring and function are the same, whichever way the product is labelled.

Power Input

- ① **Power receptacle** — A 36 W desktop power supply is provided.

ATTENTION: When the PS 1230 power supply is connected to the MPA 401, it must not be shared with any other devices.

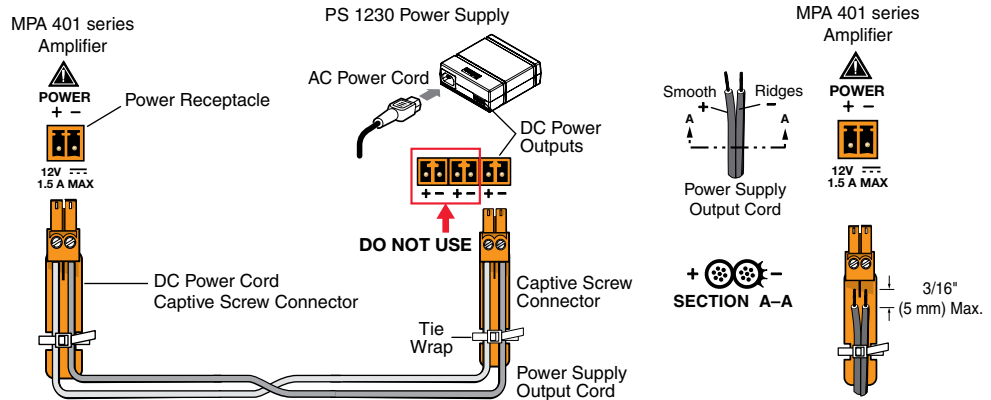

Figure 3. Connecting the PS 1230 Power Supply to an MPA 401 Amplifier

Connect one end of the DC power cord to one of the two pole, 3.5 mm captive screw outlets on the power supply. Connect the other end into the power receptacle on the rear panel of the amplifier, as shown in figure 3 above. The power cord connectors are correctly wired when shipped.

ATTENTION:

- Always use a power supply supplied by or specified by Extron. Use of an unauthorized power supply voids all regulatory compliance certification and may cause damage to the supply and the end product.
- Suitable for use in environmental air space in accordance with Section 300.22.C of the National Electrical Code, and Sections 2-128, 12-010(3) and 12-100 of the Canadian Electrical Code, Part 1, C22.1.
- Unless otherwise stated, the AC/DC adapters are not suitable for use in air handling spaces or in wall cavities. The power supply is to be located within the same vicinity as the Extron AV processing equipment in an ordinary location, Pollution Degree 2, secured to the equipment rack within the dedicated closet, podium, or desk.
- The installation must always be in accordance with the applicable provisions of National Electrical Code ANSI/NFPA 70 and the Canadian Electrical Code. The power supply shall not be permanently fixed to building structure or similar structure.
- Although the amplifier is plenum rated, the power supply provided with it is not. The power supply must not be placed in the plenum space. Cables to and from the amplifier must also be plenum rated. The DC power cord provided with the unit is not plenum rated.
- The length of the exposed wires in the stripping process is critical. The ideal length is 3/16 inches (5 mm). Any longer and the exposed wires may touch, causing a short circuit between them. Any shorter and the wires can be easily pulled out even if tightly fastened by the captive screws.

NOTE: Do not tin the wires. Tinned wire does not hold its shape and can become loose over time.

Audio Inputs

Use the rear panel receptacles (see figure at right) to connect audio sources to the amplifier. Wire the connectors as shown below. The balloon numbers refer to the figure to the right.

NOTE: The ground pins of the input receptacles may be labeled ∇ or \perp (see the images to the right). The wiring and function are the same whichever way the product is labeled.

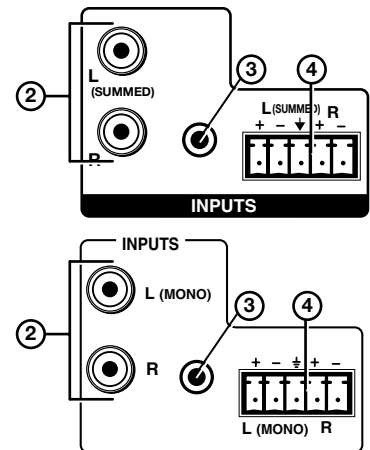

- ② **RCA input receptacles** — These receptacles accept unbalanced, line level audio signals. The input can be stereo, using two RCA connectors, or mono, using a single RCA connector plugged into the left (Summed) receptacle.
- If unused, the receptacles automatically terminate to lower the noise floor.

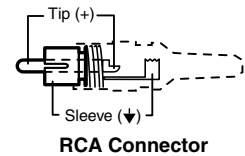

- ③ **3.5 mm TRS stereo input receptacle** — This input also accepts unbalanced, line level audio signals through a 3.5 mm tip ring sleeve (TRS) stereo connector. If unused, the receptacle automatically terminates to lower the noise floor.

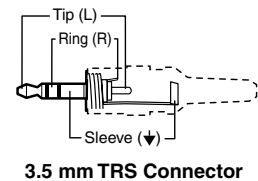

- ④ **Balanced or unbalanced input receptacle** — This 5-pole 3.5 mm captive screw receptacle accepts line level, balanced or unbalanced, mono or stereo audio signals (see the **attention** and the **note** on page 6 for important information about connecting wires to captive screw connectors).

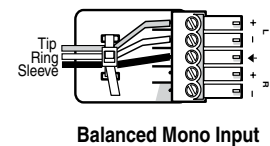
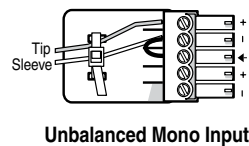
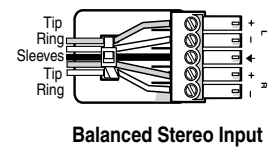
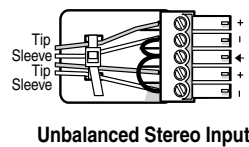

Remote Input Port

- ⑤ **Remote input port** — This 3-pin, captive screw port allows a wall-mounted audio controller to control volume and mute levels remotely (see [Remote Control Options](#) on page 12 if using a MediaLink controller).

NOTE: The remote control port may be labeled in one of two ways (see the diagram to the right). The wiring and function are the same whichever way the product is labeled.

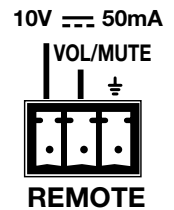
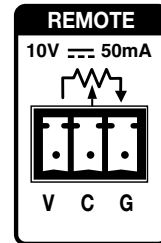

Wiring for remote control

Options for remote control include the Extron VC 50, VCM 100 AAP, VCM 100 MAAP, VCM 200 series, and MLA VC10 Plus. For information about part numbers, see www.extron.com. Third party 10k potentiometer volume controllers can also be connected to this port.

Figure 4 and the instructions below, show the wiring for the VCM 100 MAAP. Wiring other remote control connectors is similar.

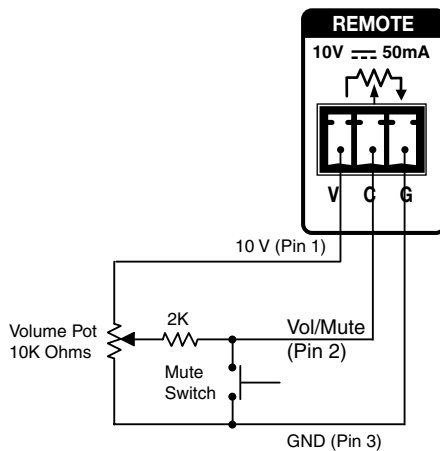

Figure 4. Remote Control Wiring

- Pin 1 is 10 VDC reference voltage.
- Pin 2 (Vol/Mute) can be used as a variable voltage input between 0 and 10 VDC, with 0 V giving full attenuation and 10 V giving maximum volume. It can also be used for remote control muting. Sound is muted while the mute pin is shorted to ground.
- Pin 3 is ground.

NOTE: All nominal levels are at $\pm 10\%$.

Controlling multiple amplifiers with one volume controller

Several MPA 401 units can be daisy-chained so that one volume controller can simultaneously regulate the volume of all the amplifiers.

NOTES:

- As additional amplifiers are added to the daisy chain, the sensitivity of the volume potentiometer will change. The maximum volume level (fully clockwise) will not be affected. However the effectiveness of the minimum volume level (fully counterclockwise) in reducing the volume to inaudible levels decreases as more amplifiers are added to the daisy chain.
- When more than two MPAs are attached to the chain, sound may begin to be heard even if the levels have been set to their lowest. The muting of the output however can be remedied with a contact closure button attached between the Vol/Mute and Ground pin of the first MPA in the chain.

To regulate multiple amplifiers with a single volume controller, follow these instructions:

1. Attach all three pins of the volume controller to the corresponding pins on the first MPA 401 unit only (ground to ground; Vol/Mute to Vol/Mute; and 10 V to 10 V).
2. Use jumper wires to connect the Vol/Mute pins of the first amplifier and each successive amplifier.
3. Use jumper wires to connect the ground pins of the first amplifier and each successive amplifier.

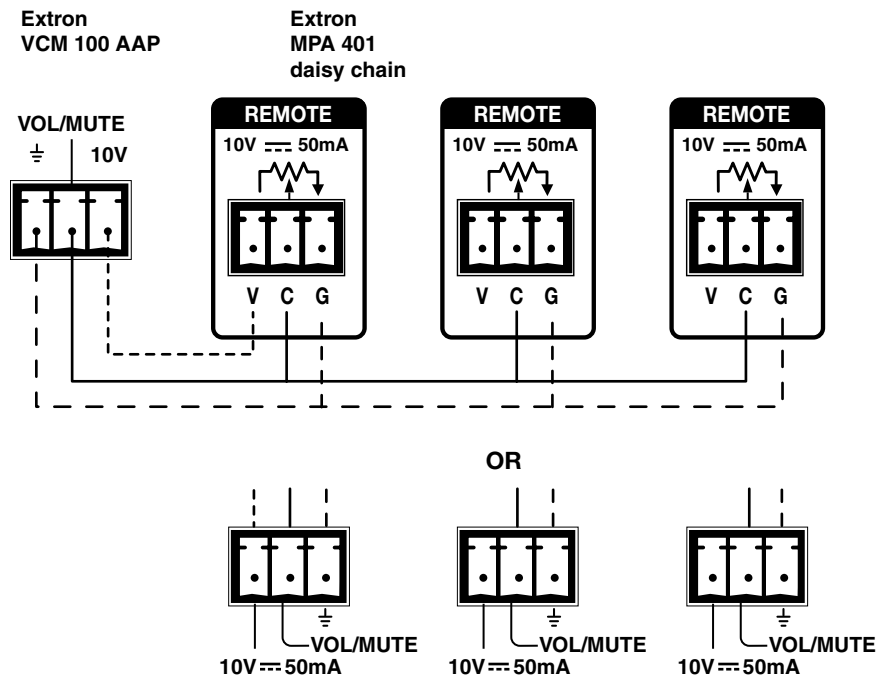
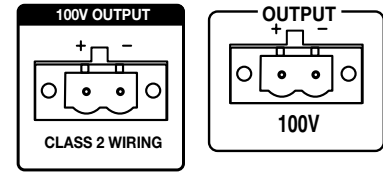

Figure 5. Regulating Multiple Amplifiers with a Single Volume Controller

NOTE: The 10V pin of the volume controller connects to the first MPA 401 only. There are no jumper wires linking it to subsequent amplifiers.

Speaker Connections

- ⑥ **Speaker receptacle (see figure 2)** — Connect the speakers to the speaker receptacle using the 2-pole, 5 mm screw-lock captive screw connector (MPA 401-100V shown at right).



NOTES:

- The mono audio speaker receptacle may be labeled in one of two ways (see the diagrams above). The wiring and function are the same whichever way the product is labeled.
- The MPA 401 amplifier sums the left and right signals from both the TRS and RCA inputs to form Sum 1. Sum 1 is then weighted. At the same time, the amplifier sums the left and right signals from the captive screw input to form Sum 2. Sum 1 and Sum 2 are then summed together to form a single mono signal. See figure 6 below for more details.
- The captive screw, RCA and TRS inputs are buffered.

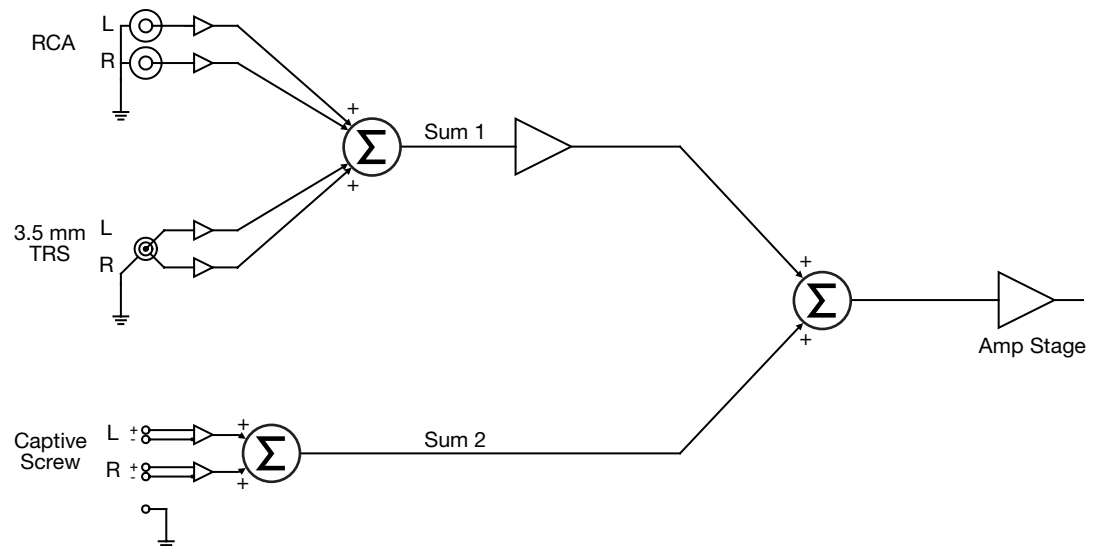

Figure 6. Summing MPA 410 input signals to form a single mono output signal

The MPA 401-70V provides up to 40 W for a 70 V line distributed sound system; the MPA 401-100V provides up to 40 W for a 100 V line distributed sound system.

See the **attention** and the **note** on page 6 for important information about connecting wires to captive screw connectors.

ATTENTION: Do not ground or short the speaker outputs as this will damage the amplifier.

Setup and Operation

This section provides information about the front panel features and operation of the MPA 401-70V and MPA 401-100V:

- [Front Panel Features](#)
- [Setting Input Level](#)
- [Setting Bass and Treble](#)
- [Remote Control Options](#)
- [Troubleshooting](#)

Front Panel Features

The front panels of the MPA 401-70V and MPA 401-100V are identical and shown below:

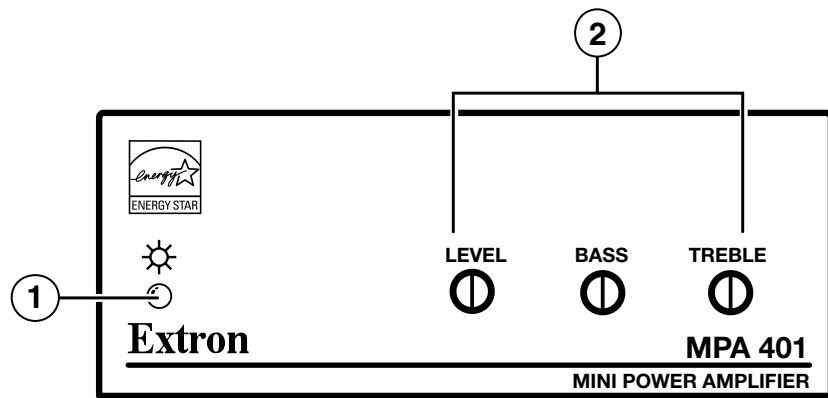

Figure 7. MPA 401-70V or MPA 401-100V Front Panel

- ① **Power LED** — The LED lights green when the MPA 401 unit is receiving power and active. It lights amber when the unit is on standby.
- ② **Potentiometers** — These three front panel potentiometers are used to optimize level, bass, and treble settings (see the following pages for further details).

Setting Input Level

Adjust the input level as follows:

1. If necessary, unplug the remote connector from the unit.
2. If connecting the amplifier to a system with adjustable volume, set the volume to its lowest point. Then adjust the level potentiometer fully counterclockwise to its minimum setting.
3. Set the system volume to its maximum level. No sound should come out.
4. Slowly increase the amplifier level until sound distortion starts to occur. Lower the level slightly until the distortion disappears. This setting ensures that, whatever the system volume setting may be, no clipping occurs.

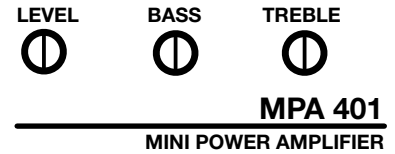

Setting Bass and Treble

Adjust the bass and treble as follows:

1. Use the bass potentiometer to increase or decrease the bass shelving ± 10 dB at 100 Hz and below.
2. Use the treble potentiometer to increase or decrease the treble shelving ± 10 dB at 10 kHz and above.

NOTE: Turning the bass or treble potentiometers counterclockwise will decrease the output at the specified frequencies. Turning the potentiometers clockwise will increase the output. When the potentiometer is at the center detent, flat response is achieved.

Remote Control Options

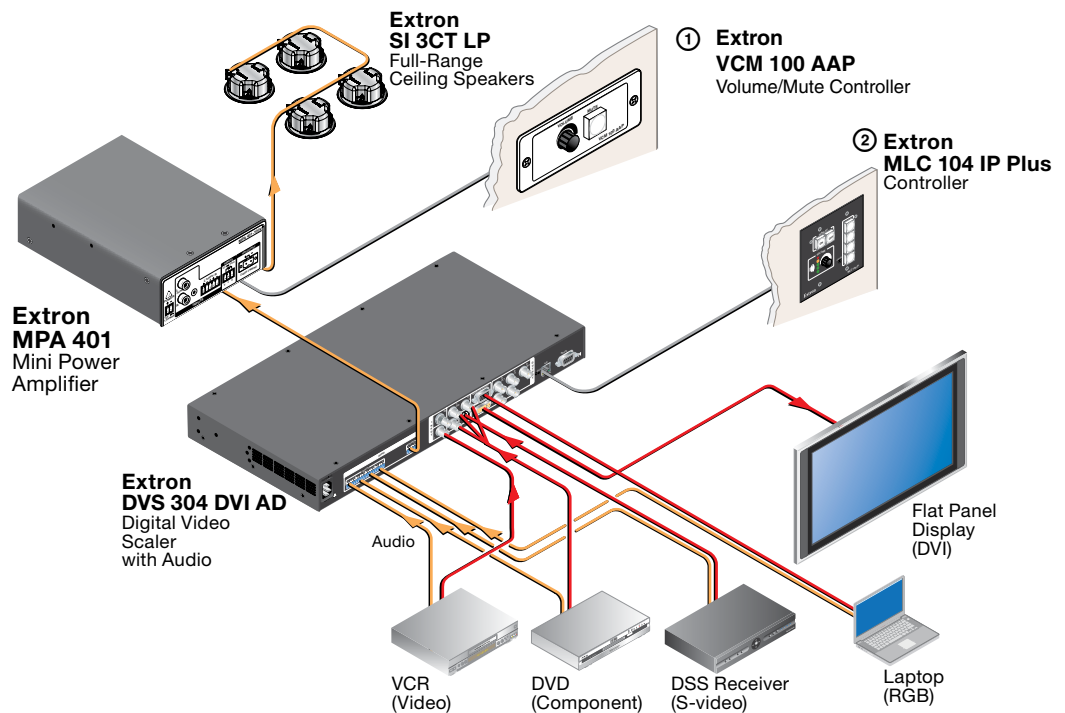

Figure 8. MPA 401 Remote Control Options

- 1. Extron VCM 100 AAP volume and mute control** — For a system designed to control the volume of the amplifier directly, use a 10k Ohm potentiometer to control volume via the remote port on the amplifier. Follow the instructions in the product guide.
- 2. Using a MediaLink Controller** — For a system with variable audio output, connect the audio output to the audio input of the amplifier. In the above example, a MediaLink controller adjusts the audio volume via a network connection. Follow the instructions in the product guide.

Troubleshooting

Under different circumstances, the front panel LED lights green or amber, which provides diagnostic information.

Amplifier Fails to Exit Standby Mode Promptly

Power LED Color	Problem Description	Problem Solution
Amber	No output signal.	<ul style="list-style-type: none">No input detected: verify that there is an input signal. If a signal is present, raise the input level.The amplifier is in standby mode and the output has been turned off. Check the remote port.
Green or Amber	Slow to exit standby mode when a signal is present.	<ul style="list-style-type: none">The input signal may be too weak. Raise the input level.

Amplifier Enters Standby Mode Too Early

Power LED Color	Problem Description	Problem Solution
Green or Amber	Enters standby mode early.	<ul style="list-style-type: none">The input signal may be too weak. Raise the input level.

Reference Material

This section of the user guide contains information about [Mounting](#) the MPA 401.

Mounting

Plenum Placement

The MPA 401-70V and MPA 401-100V amplifiers meet UL 2043 requirements for heat and smoke release. They can be installed in the ceiling, out of sight, with reduced risk of theft.

ATTENTION: Although the amplifier is plenum rated, the power supply provided with it is not. The power supply must not be placed in the plenum space. Cables to and from the amplifier must also be plenum rated. The DC power cord provided with the unit is not plenum rated.

Tabletop Placement

Attach the four provided rubber feet to the bottom of the unit and place it in any convenient location.

Rack Mounting

UL Guidelines For Rack Mounting

The following Underwriters Laboratories (UL) guidelines are relevant to the safe installation of these products in a rack:

- 1. Elevated operating ambient temperature** — If the unit is installed in a closed or multi-unit rack assembly, the operating ambient temperature of the rack environment may be greater than room ambient temperature. Therefore, install the equipment in an environment compatible with the maximum ambient temperature (T_{ma}: +122 °F, +50 °C) specified by Extron.
- 2. Reduced air flow** — Install the equipment in the rack so that the equipment gets adequate air flow for safe operation.
- 3. Mechanical loading** — Mount the equipment in the rack so that uneven mechanical loading does not create a hazardous condition.
- 4. Circuit overloading** — Connect the equipment to the supply circuit and consider the effect that circuit overloading might have on overcurrent protection and supply wiring. Appropriate consideration of the equipment nameplate ratings should be used when addressing this concern.
- 5. Reliable earthing (grounding)** — Maintain reliable grounding of rack-mounted equipment. Pay particular attention to supply connections other than direct connections to the branch circuit (such as the use of power strips).

ATTENTION: Use only the two holes indicated in figure 9 for mounting the MPA 401. The other four holes anchor stand-offs for the internal circuit boards; using them may damage the amplifier and will not provide secure mounting for the unit.

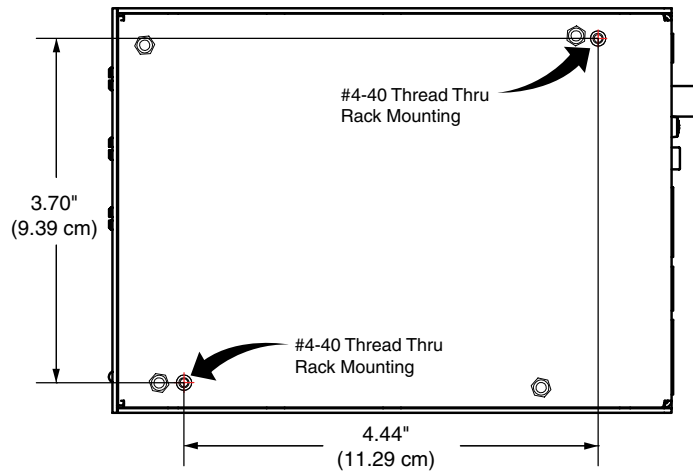

Figure 9. Points for Securing the Base of the MPA 401 to a Rack

Rack Mounting Procedure

To mount the amplifier on a rack shelf, follow the instructions provided with the shelf accessories.

Under-desk, Through-desk, and Projector Mounting

The amplifier can be mounted under or through a desk, or above a projector. For the appropriate mounting kit, see www.extron.com. Follow the instructions provided with each kit.

Extron Warranty

Extron Electronics warrants this product against defects in materials and workmanship for a period of three years from the date of purchase. In the event of malfunction during the warranty period attributable directly to faulty workmanship and/or materials, Extron Electronics will, at its option, repair or replace said products or components, to whatever extent it shall deem necessary to restore said product to proper operating condition, provided that it is returned within the warranty period, with proof of purchase and description of malfunction to:

USA, Canada, South America, and Central America:

Extron Electronics
1230 South Lewis Street
Anaheim, CA 92805
U.S.A.

Japan:

Extron Electronics, Japan
Kyodo Building, 16 Ichibancho
Chiyoda-ku, Tokyo 102-0082
Japan

Europe and Africa:

Extron Europe
Hanzeboulevard 10
3825 PH Amersfoort
The Netherlands

China:

Extron China
686 Ronghua Road
Songjiang District
Shanghai 201611
China

Asia:

Extron Electronics Asia Pte. Ltd.
135 Joo Seng Road, #04-01
PM Industrial Bldg.
Singapore 368363
Singapore

Middle East:

Extron Middle East
Dubai Airport Free Zone
F12, PO Box 293666
United Arab Emirates, Dubai

This Limited Warranty does not apply if the fault has been caused by misuse, improper handling care, electrical or mechanical abuse, abnormal operating conditions, or if modifications were made to the product that were not authorized by Extron.

NOTE: If a product is defective, please call Extron and ask for an Application Engineer to receive an RA (Return Authorization) number. This will begin the repair process.

USA: 714.491.1500 or 800.633.9876
Asia: 65.6383.4400

Europe: 31.33.453.4040
Japan: 81.3.3511.7655

Units must be returned insured, with shipping charges prepaid. If not insured, you assume the risk of loss or damage during shipment. Returned units must include the serial number and a description of the problem, as well as the name of the person to contact in case there are any questions.

Extron Electronics makes no further warranties either expressed or implied with respect to the product and its quality, performance, merchantability, or fitness for any particular use. In no event will Extron Electronics be liable for direct, indirect, or consequential damages resulting from any defect in this product even if Extron Electronics has been advised of such damage.

Please note that laws vary from state to state and country to country, and that some provisions of this warranty may not apply to you.

Extron Headquarters +1.800.633.9876 (Inside USA/Canada Only) Extron USA - West +1.714.491.1500 Extron USA - East +1.919.850.1000 +1.714.491.1517 FAX +1.919.850.1001 FAX	Extron Europe +800.3987.6673 (Inside Europe Only) +31.33.453.4040 +31.33.453.4050 FAX	Extron Asia +65.6383.4400 +65.6383.4664 FAX	Extron Japan +81.3.3511.7655 +81.3.3511.7656 FAX	Extron China +86.21.3760.1568 +86.21.3760.1566 FAX	Extron Middle East +971.4.299.1800 +971.4.299.1880 FAX	Extron Korea +82.2.3444.1571 +82.2.3444.1575 FAX	Extron India 1800.3070.3777 (Inside India Only) +91.80.3055.3777 +91.80.3055.3737 FAX
---	--	--	---	---	---	---	--